

F-box genes and the evolution of the S-locus in the Pyrinae

Paolo De Franceschi, Luca Pierantoni,
Luca Dondini, Marco Grandi and
Silviero Sansavini
Dipartimento di Colture Arboree (DCA)
Università di Bologna
Via Fanin 46, 40127 Bologna, Italy
pdefra@agrsci.unibo.it

Javier Sanzol
Unidad de Fruticultura
Centro de Investigación y Tecnología
Agroalimentaria de Aragón (CITA)
Avenida de Montañana 930, 50059
Zaragoza, (Spain)

Keywords: pear, apple, self-incompatibility, S-RNase, SFBB

Abstract

The *Malus* (apple) and *Pyrus* (pear) genera belong to the subtribe Pyrinae, formerly known as the subfamily Maloideae. Like many other species of the Rosaceae, they exhibit a gametophytic self-incompatibility (GSI) mechanism which is genetically determined by a single multigenic and highly polymorphic locus (S-locus). The S-locus controls pollen-pistil recognition through different genes; a stylar ribonuclease (S-RNase) is the female (pistil) determinant whereas its male (pollen) counterpart(s) might consist of one or more F-box proteins. The present study reports the characterization of S-locus F-box genes from a group of apple and pears (European, Japanese and Chinese pear) cultivars, selected on the basis of their S-allele composition. The S-locus structure and diversity in the Pyrinae is analyzed considering the number of F-box genes characterized for each S-haplotype, their genetic linkage to the S-RNase and their phylogenetic relationships within and among species. Our results provide new insight into the evolution of the S-locus within this taxonomic group, and the role that the different S-locus F-box genes might have in self-incompatibility.

INTRODUCTION

Gametophytic Self-Incompatibility (GSI) is a system that prevents self-fertilization, inhibiting the growth of pollen tubes recognized as “self” in the upper part of the style. The specificity of the recognition mechanism depends on a single locus, the S-locus, that harbors at least two different genes: a female determinant, expressed in the pistil tissues, and a male one, expressed in pollen. A pollen tube is rejected when its haploid genome carries a S-allele that matches one of those harbored by the pistil. S-RNase-based GSI is the most widespread mechanism, being present in members of three distantly-related families of flowering plants: Rosaceae, Solanaceae and Plantaginaceae. In this mechanism the female determinant is a stylar glycoprotein with ribonuclease activity, the S-RNase, whereas its pollen counterpart is a protein containing an F-box domain.

In the genera *Petunia* (Solanaceae), *Antirrhinum* (Plantaginaceae) and *Prunus* (Rosaceae), in which the pollen S determinant has already been identified after transformation experiments or mutant characterization, it proved to be coded by a single gene (Sijacic et al. 2004; Qiao et al. 2004; Ushijima et al. 2004). Nevertheless, in apple (*Malus × domestica*) and Japanese pear (*Pyrus pyrifolia*), two species belonging to the subtribe Pyrinae of the Rosaceae, multiple F-box genes have been identified in the genomic region surrounding the S-RNase (Sassa et al. 2007); these genes have been

named S-locus F-Box Brothers (SFBB) and are considered good candidates for the pollen S, since they exhibit S-haplotype-specific polymorphism, linkage to the S-RNase and pollen-specific expression.

An unexpected difference was however observed between the apple and the Japanese pear SFBBs. The three SFBBs identified in pear highlighted a very high homology within each gene (PpSFBB- α , β and γ , "Pp" standing for *Pyrus pyrifolia*), suggesting that these genes originated before the divergence of their respective S-haplotypes; on the contrary, for the two apple genes (MdSFBB- α and β , "Md" standing for *Malus × domestica*) the highest similarity was found between genes belonging to the same haplotype (Fig. 1). The diversification patterns of the S-locus F-box genes in the Pyrinae was thus unclear.

In the present study we cloned SFBB homologs from apple and three different pear species: European (*Pyrus communis*), Japanese (*P. pyrifolia*) and Chinese pear (*P. × bretschneideri*); to test their linkage to the S-locus, they were mapped on an European pear population consisting of 92 individuals. We then carried out a comparative analysis of the SFBB and S-RNase phylogenetic profiles, in order to better understand their mechanism of diversification and thus to get clues on their possible role in self-incompatibility.

MATERIALS AND METHODS

A preliminary analysis was carried out on the S-RNase gene sequences of apple, European, Japanese and Chinese pear available in the GenBank. Three groups of S-RNases belonging to different species but showing a high sequence homology were chosen: apple S₉/European pear S₁₂₃/Chinese pear S₁₆; apple S₁₀/European pear S₁₀₃; European pear S₁₁₁/Japanese pear S₁ (Fig. 2).

Cultivars were chosen among those harboring the selected S alleles, plus the European pear varieties 'Abbé Fétel' and 'Max Red Bartlett', for which a segregating population of 92 individuals and a linkage map was already available at the DCA of Bologna. The pool of genotypes finally consisted of the apple cultivars 'Fuji' (S₁/S₉) and 'McIntosh' (S₁₀/S₂₅); the European pear 'Abbé Fétel' (S₁₀₄/S₁₀₅), 'Max Red Bartlett' (S₁₀₁/S₁₀₂), 'Conseiller a la Coeur' (S₁₀₃/S₁₂₃), 'Pacham's Triumph' (S₁₀₁/S₁₀₃) and 'Wilder' (S₁₀₁/S₁₁₁); the Japanese pear 'Kumoi' (S₁/S₃); and the Chinese pear 'Xue Hua Li' (S₁₆/S₃₉).

Primer pairs were developed on the apple and Japanese pear SFBB genes reported by Sassa et al., 2007.. Three primer pairs were directed to the amplification of homologs to the three Japanese pear genes PpSFBB- α , β and γ ; each pair was developed on conserved regions of the different alleles of the same gene. For the apple genes, a specific primer pair was developed on each of the two SFBBs (α and β) belonging to the two haplotypes from which they were isolated (S₃ and S₉). The obtained sequences were aligned and phylogenetic trees were constructed using the neighbor-joining algorithm. The genes were moreover mapped in the 'Abbé Fétel' × 'Max Red Bartlett' population.

RESULTS

For five of the SFBBs (PpSFBB- α , β and γ , MdSFBB3- β and MdSFBB9- β), homologs were obtained from the great majority of the cultivars belonging to the four species, suggesting that they constitute five classes maintained in the great majority of the Pyrinae S-haplotypes; these genes were thus named SFBB α to ϵ , with SFBB α , β and γ respectively homologous to PpSFBB- α , β and γ , SFBB δ homologous to MdSFBB3- β and SFBB ϵ to MdSFBB9- β . On the contrary, homologs to the MdSFBB9- α gene could be

amplified only from three genotypes: apple 'Fuji', European pear 'Conseiller a la Coeur' and Chinese pear 'Xue Hua Li'; not surprisingly, these cultivars are those carrying the highly conserved S-RNases alleles apple S₉, E. pear S₁₂₃ and C. pear S₁₆; these genes were called hMdSFBB9- α ("h" standing for homologous). Finally, no homologs were identified for MdSFBB3- α .

As expected, all the SFBB genes showed S-haplotype-specific polymorphisms: identical sequences were thus obtained from, and only from, genotypes carrying a common S-allele. The SFBB- α to ϵ genes were mapped in the 'Abbé Fétel' \times 'Max Red Bartlett' population: all of them showed a tight linkage to the S-RNase, and were placed in the bottom of linkage group 17, that corresponds to the known map position of the S-locus both in apple and pear (Fig.3). However, not all the SFBBs exhibited a full linkage with the S-RNase gene: very rare recombination events between the S-RNase and, the SFBB α and SFBB γ genes could be identified. These two genes were thus placed outside the S-locus, even though in close proximity. SFBB δ and SFBB ϵ fully co-segregated with the S-RNase and can be considered to belong to the S-locus. A more complex situation was encountered for SFBB β , for which more than two different sequences could be obtained from a single haplotype, suggesting gene duplication(s) events.

The phylogenetic trees constructed for the five SFBBs highlighted two very different structures, exemplified by the SFBB α and SFBB δ trees in figure 4. SFBB α and SFBB γ exhibited a very low sequence divergence; moreover, the sequences obtained from apple formed a clearly separated cluster from those obtained from the three *Pyrus* species; i.e., sequence clustering reflected the genera divergence. This structure is very different from that of the S-RNase genes, for which the highest homology can be identified between alleles belonging to different species. On the contrary, the SFBB δ and SFBB ϵ genes showed a higher sequence divergence, although it resulted still much lower than that of the S-RNase. No separation between the *Malus* and *Pyrus* sequences could be observed for these genes, thus suggesting a clustering that is more compatible with the features exhibited by the S-RNase. Moreover, a pattern of co-evolution could be observed between some branches of the SFBB δ and SFBB ϵ trees, and the S-RNase one: the S-haplotypes showing highly conserved S-RNase alleles, also exhibited a high homology in the SFBB δ and SFBB ϵ genes (Fig. 5).

DISCUSSION

In the subtribe Pyrinae of the Rosaceae, the S-locus region is characterized by the presence of a number of F-box genes, called SFBBs. In the present study at least five genes (SFBB α to ϵ) proved to be present in the majority of S-haplotypes of apple and European, Japanese and Chinese pears. However one of these genes (SFBB β) seemed to be duplicated at least in some haplotypes; moreover, one more conserved gene was identified in three S-haplotypes of three different species (hMdSFBB9- α); thus, the number of F-box genes linked to each haplotype can't still be accurately determined, even though it proved to be higher than previously reported. The good degree of conservation of these genes in the four species suggest that the Pyrinae share a common S-locus structure, with SFBBs spread in a large genomic region surrounding the S-RNase (Fig. 6); this region is extended even outside the S-locus: at least two SFBBs (α and γ) evidenced rare recombination events with the S-RNase gene; these two genes thus, despite their tight linkage to the S-locus, cannot be considered as belonging to it.

A phylogenetic analysis was moreover carried out on SFBBs. The male and female S genes are supposed to co-evolve, since the generation of a new S specificity

requires a coordinated change in both genes. The S-locus is subject, in natural conditions, to a frequency-dependent balancing selection: an individual carrying a very rare S-allele has increased mating chances, since its pollen grains will be accepted from the great majority of other plants. Thus, the frequency of a rare allele tends to increase with the generations, rather than being lost. For this reason S-alleles are maintained for extremely long periods, even longer than the average lifetime of a species: this phenomenon, referred as trans-specific evolution, results in the presence of extremely conserved alleles between different but related species. This situation is clearly visible in the Pyrinae S-RNases, that exhibit an high degree of polymorphism within the same specie, but highlight as well the presence of almost identical alleles between different species. Given that male and female S genes must co-evolve, the same phylogenetic features can be expected for the pollen S; the analysis of phylogenetic profiles of SFBBs was thus used as a tool to evaluate the possible role of SFBBs as candidates for the pollen S of Pyrinae.

Not surprisingly, the different distances of SFBBs from the S-RNase resulted in different phylogenetic profiles. The genes placed at higher distance exhibited a lower degree of polymorphism and a clustering that reflected the genera divergence, with the sequences obtained from *Malus* being clearly separated from those from *Pyrus*. SFBBs that are placed closer to the S-RNase, and most likely within the S-locus, resulted more polymorphic and, similarly to the S-RNase, exhibited the highest similarity between alleles isolated from different species. Moreover, correspondence was found between some branches of the S-RNase and the SFBBs phylogenetic trees: S-haplotypes of different species having extremely conserved S-RNases also displayed highly homologous SFBB sequences. Finally, we observed that homologs to MdSFBB9- α were found in those European and Chinese pear haplotypes that possess S-RNase alleles with the highest homology to the apple S₉-RNase, from which MdSFBB9- α was first characterized.

Altogether these results provided evidence of shared ancestral polymorphism between different Pyrinae S-haplotypes, and co-evolution between the S-RNase and the SFBBs placed in its close proximity (SFBB δ , SFBB ϵ , hMdSFBB9- α). Even though the co-evolution of two genes does not necessarily imply a functional relationship between them, these genes can be considered the best candidates for the pollen S factor in the Pyrinae. It is possible that, like in *Petunia*, *Antirrhinum* and *Prunus*, the male S determinant in the Pyrinae is coded by a single gene, but at present it can't be excluded the possibility that multiple genes participate in a coordinated manner to determine the pollen S function. On the other hand, SFBB α and SFBB γ proved to be placed outside the S-locus, and both for their map position and their phylogenetic profile, these genes could be excluded from the list of candidates for this role. The high number of F-box genes might be considered a distinctive feature of the Pyrinae S-locus region; however, further investigation is needed both to understand their biological functions, and to identify which one(s) is responsible for the pollen S function.

ACKNOWLEDGEMENTS

This research work was supported by the PRIN project (MIUR, Rome) 2007 and by "Ministerio de Ciencia e Innovación de España"- EU-FEDER (project grant CICYT AGL2009-12621-C02-02). J.S. acknowledges the "Instituto de Investigación y Tecnología Agroalimentaria"-INIA_CCAA program and the "Ministerio de Ciencia e Innovación de España" - I3 program for financial support.

Literature cited

- De Franceschi, P., Pierantoni, L., Dondini, L., Grandi, M., Sanzol, J. and Sansavini, S. 2010a. Cloning and mapping multiple S-locus F-box genes in European pear (*Pyrus communis* L.). *Tree Genet. Genomes*, DOI 10.1007/s11295-010-0327-5.
- De Franceschi, P., Pierantoni, L., Dondini, L., Grandi, M., Sansavini, S. and Sanzol, J. 2010b. Evaluation of candidate F-box genes for the pollen S of gametophytic self-incompatibility in the Pyrinae (Rosaceae), on the basis of their phylogenomic context. Submitted.
- Qiao, H., Wang, F., Zhao, L., Zhou, J., Lai, Z., Zhang, Y., Robbins, T.P. and Xue, Y. 2004. The F-box protein AhSLF-S2 controls the pollen function of S-RNase-based self-incompatibility. *Plant Cell* 16:2307-2322
- Sassa, H., Kakui, H., Miyamoto, M., Suzuki, Y., Hanada, T., Ushijima, K., Kusaba, M., Hirano, H. and Koba, T. 2007. S locus F-box brothers: multiple and pollen-specific F-box genes with S haplotype-specific polymorphisms in apple and Japanese pear. *Genetics* 175:1869-1881
- Sijacic, P., Wang, X., Skirpan, A.L., Wang, Y., Dowd, P.E., McCubbin, A.G., Huang, S. and Kao, T.H. 2004. Identification of the pollen determinant of S-RNase-mediated self-incompatibility. *Nature* 429:302-305
- Ushijima, K., Yamane, H., Watari, A., Kakehi, E., Ikeda, K., Hauck, N.R., Iezzoni, A.F. and Tao, R. 2004. The S haplotype-specific F-box protein gene, SFB, is defective in self-compatible haplotypes of *Prunus avium* and *P. mume*. *Plant J.* 39:573-586

Figures

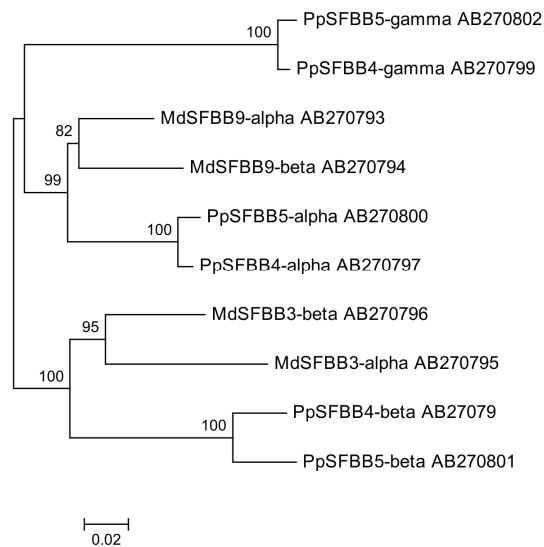

Fig. 1. Neighbor-joining tree of the S-locus F-Box Brothers identified in apple (MdSFBBs) and Japanese pear (PpSFBBs) (Sassa et al. 2007). The genes from Japanese pear show a good homology within the three groups alpha, beta and gamma, whereas the genes from apple show higher homology between genes of the same haplotype (e.g. 9-alpha with 9-beta) rather than within the alpha or beta groups.

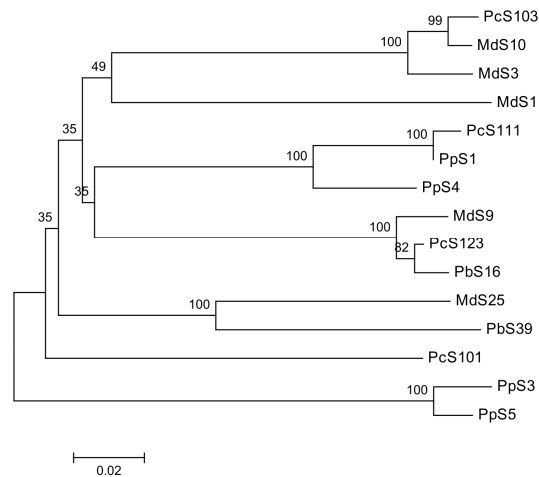

Fig. 2. Phylogenetic tree of the S-RNase alleles carried by the apple and pear cultivars used in this study; each allele is preceded by “Md” for *Malus × domestica*, “Pc” for *Pyrus communis*, “Pp” for *P. pyrifolia* and “Pb” for *P. × bretschneideri*. Note the three clusters of highly homologous alleles from different species: PcS₁₀₃/MdS₁₀; PcS₁₁₁/PpS₁; MdS₉/PcS₁₂₃/PbS₁₆.

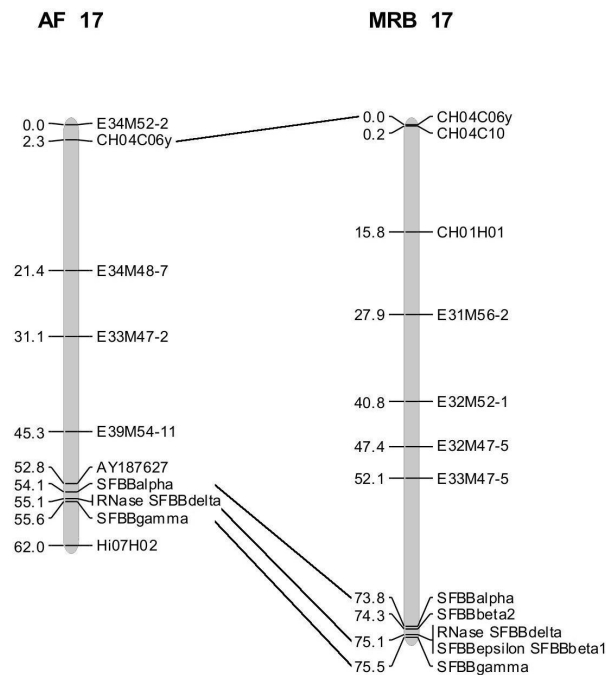

Fig. 3. Graphical representation of linkage group 17 of 'Abbé Fétel' (AF) and 'Max Red Bartlett' (MRB), where the SFBB genes have been mapped. SFBB δ and SFBB ϵ co-mapped with the S-RNase, whereas SFBB α and SFBB γ were placed in its proximity; SFBB β proved to be duplicated in 'Max Red Bartlett', with only one copy fully co-segregating with the S-RNase. Source: De Franceschi et al. 2010a.

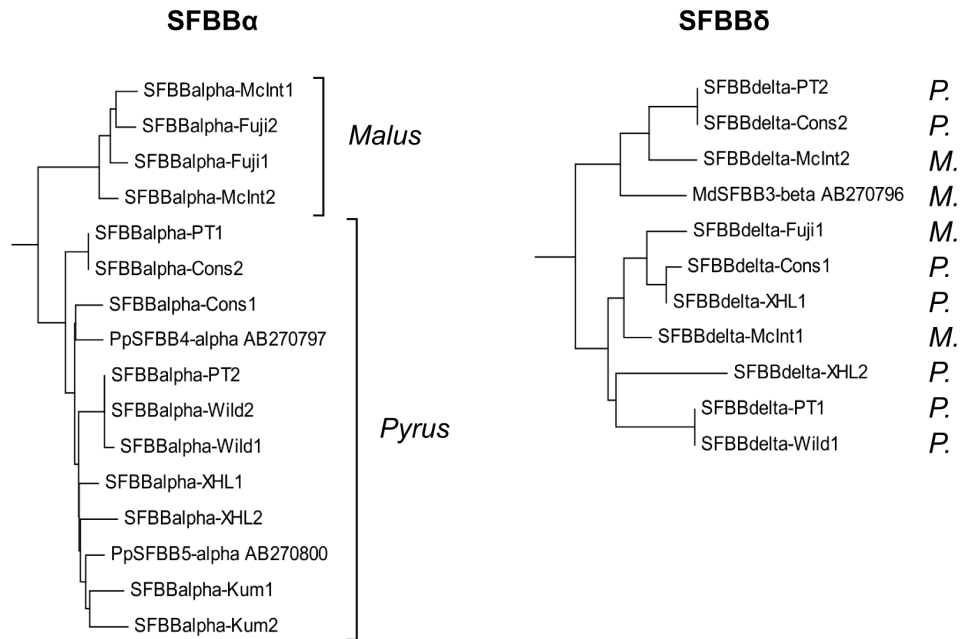

Fig. 4. Comparison between the phylogenetic profiles of SFBB α (left) and SFBB δ (right). Each sequence is reported with an abbreviation for the name of the cultivar of origin: apple 'McIntosh' ("McInt"), 'Fuji'; European pear 'Conseiller a la Coeur' ("Cons"), Packham's Triumph ("PT"), 'Wilder' ("Wild"); Japanese pear 'Kumoi' ("Kum"); Chinese pear 'Xue Hua Li' ("XHL"). The sequences of PpSFBB α and MdSFBB3- β genes described by Sassa et al. (2007) are reported with their accession numbers. The SFBB α tree highlights a clear separation between the sequences obtained from apple (*Malus*) and those from the three pear species (*Pyrus*); in the SFBB δ tree, on the contrary, sequences from *Malus* (marked as "M." on the right) cluster together with those from *Pyrus* ("P.").

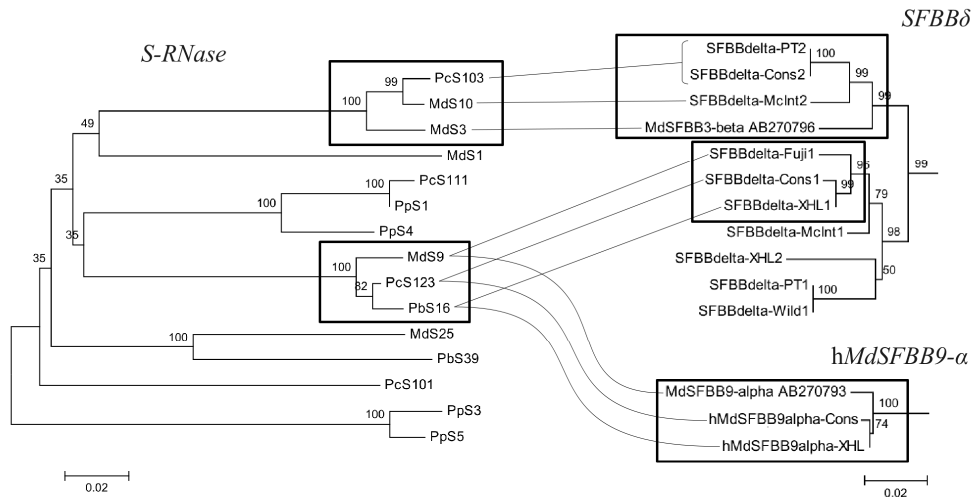

Fig. 5. Comparison between the S-RNase tree (left) and those of SFBB δ and hMdSFBB9- α (right); lines are used to connect SFBB alleles with their cognate S-RNases. The cluster structure, highlighted by squares, is maintained within the groups of highly conserved S-haplotypes, both for S-RNases and SFBBs. Source: adapted from De Franceschi et al. 2010b.

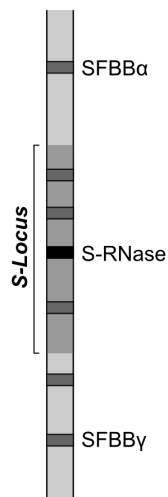

Fig. 6. The deduced structure of the S-locus region of the Pyrinae. The S-RNase gene (in black) is surrounded by a number of F-box genes (dark gray); some of them actually belong to the S-locus, whereas others (among which SFBB α and SFBB γ) are placed outside it.